



Luminator sensor with two weatherproof, corrosionproof floodlights and round mounting plate. PRE-WIRED FOR EASY INSTALLATION. Both floods and sensor have universal ball swivels for easy tool-less adjustment. Lamps not supplied.

Color: White

Weight: 1.2 lbs

Project:	Type:
Prepared By:	Date:

Technical Specifications

Listings

UL Listing:

Suitable for wet locations.

Electrical

Voltage:

120 volts AC 60 Hz.

Power Consumption:

1W

Photo Control:

Deactivates lights during daylight.

Wall Switch Manual Override:

Two flip logic prevents activation by momentary power outages. Override resets to auto after 6 hours or at dawn. No extra wiring needed.

Surge Protection:

Withstands up to 3000 volts.

Switching Capacity:

300 watts incandescent @ 120 volts, 2.5 amps.

Sensor Characteristics

Time Adjustment:

8 seconds to 10 minutes.

Auto Test Logic:

5 minutes of test time when power is turned on, Rests to auto mode without further adjustment.

Sensor Housing:

Made of tough, corrosion resistant polycarbonate.

Detection:

110° view.

Other

Detector Sensitivity:

Adjustable from 100% to 50%.

Warranty:

3 year sensor warranty.

Construction

Floodlights:

Made of tough, corrosion-resistant polycarbonate. Accepts PAR-38 lamps, medium base, 150 watts max. Lamps not included.

Dimensions

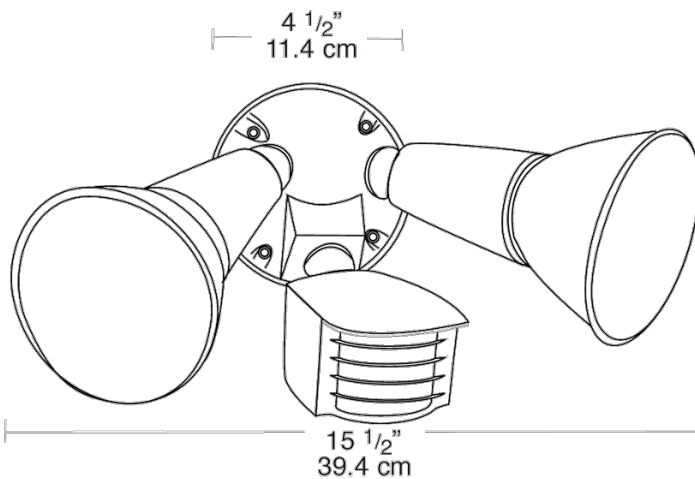

Features

- 300 Watt switching capacity
- Manual override
- Fully adjustable positioning
- 110° double look down lens
- Tough, vandal resistant lens and grill
- LS300 fits 1/2" standard threaded cover plates
- 3 year warranty