

Die cast aluminum for thru-wall or conduit end floodlight mounting. Three 1/2" threaded holes. Side opening cover for easy access and splicing. 1/2" thru wall tapped hub.

Color: Natural

Weight: 0.4 lbs

<b>Project:</b>	<b>Type:</b>
<b>Prepared By:</b>	<b>Date:</b>

## Technical Specifications

### Listings

#### UL Listing:

Suitable for wet locations.

#### Other

#### Outlet Box Construction:

Precision die cast aluminum.

#### Country of Origin:

Designed by RAB in New Jersey and assembled in Taiwan.

#### Trade Agreements Act Compliant:

This product is a product of Taiwan and a "designated country" end product that complies with the Trade Agreements Act.

#### GSA Schedule:

Suitable in accordance with FAR Subpart 25.4.

#### Construction

#### Outlet Box Mounting Lugs:

16 gauge corrosion protected steel with Phillips Flat head mounting screws.

#### Ground Screw:

#10-24 Green corrosion protected steel slotted hex washer head screw provided in pre-tapped hole.

## Dimensions

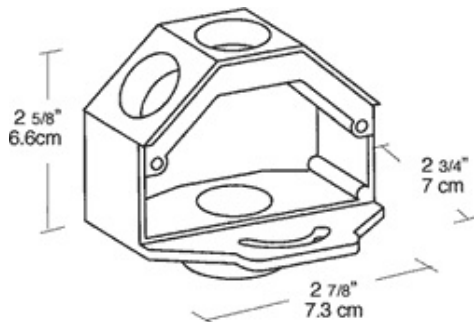

## Features

- Die cast aluminum
- Three 1/2" threaded holes
- 1/2" thru wall tapped hub